

5.37-07 SHOWN

5.35-07 - 240V	P/N : 34337-101	SUBREV : F
DRAWN BY : C THOMSON	DATE : 26 JUL 2011	SHEET 1 OF 6

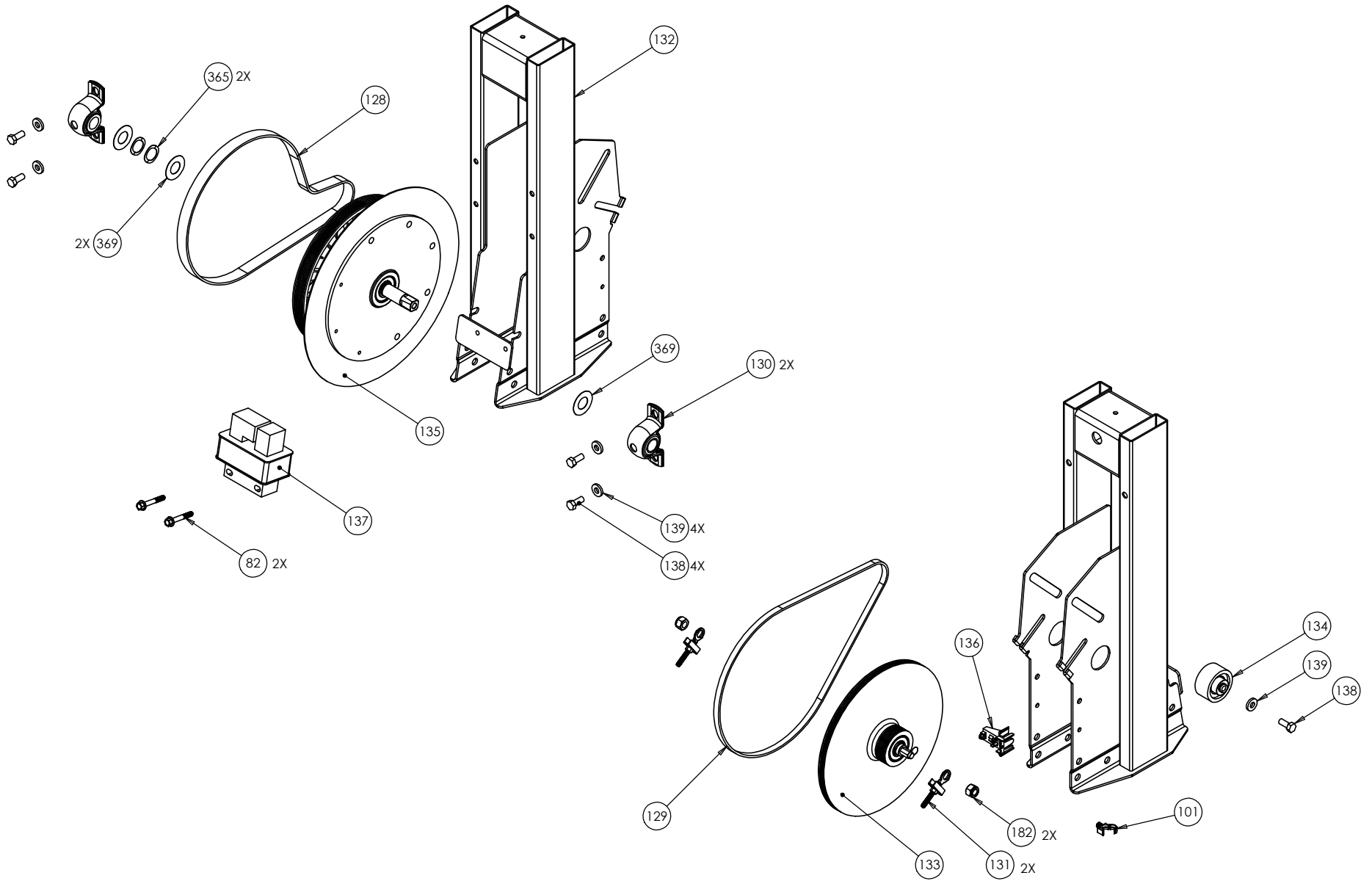

5.35-07 - 240V	P/N : 34337-101	SUBREV : F
DRAWN BY : C THOMSON	DATE : 26 JUL 2011	SHEET 3 OF 6

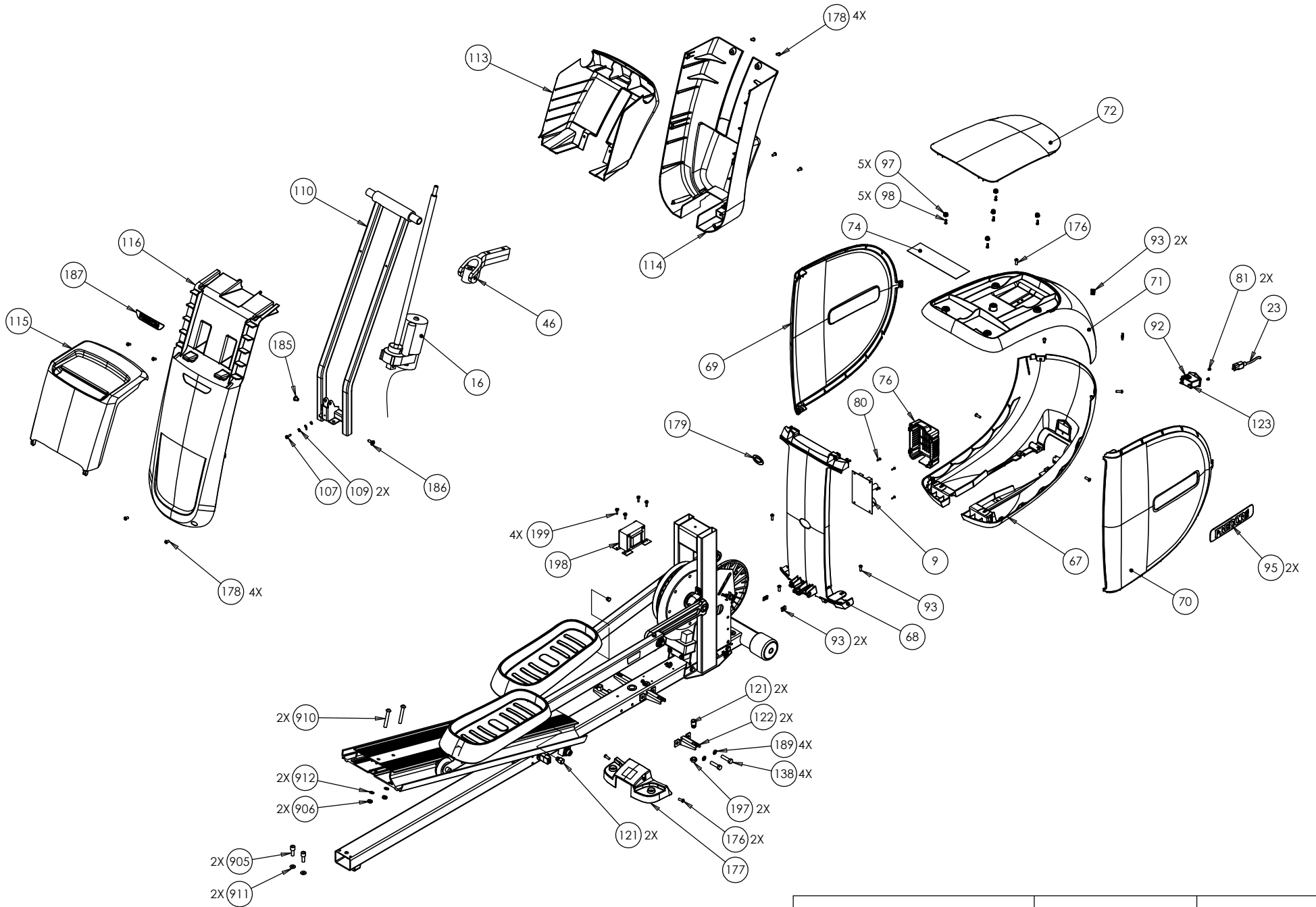

5.35-07 - 240V	P/N : 34337-101	SUBREV : F
DRAWN BY : C THOMSON	DATE : 26 JUL 2011	SHEET 4 OF 6

5.37-07 HANDLEBAR

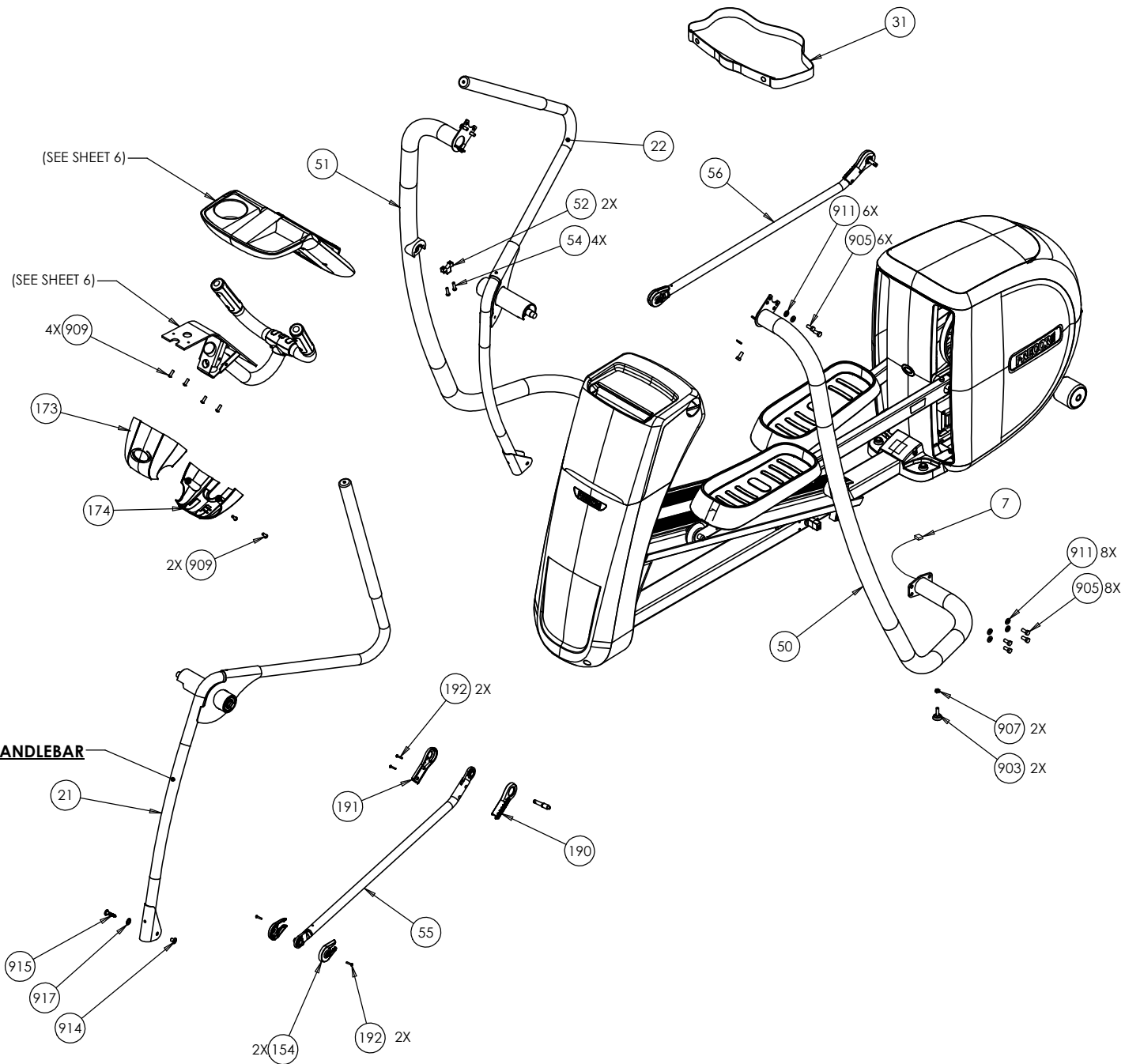

5.35-07 - 240V	P/N : 34337-101	SUBREV : F
DRAWN BY : C THOMSON	DATE : 26 JUL 2011	SHEET 5 OF 6

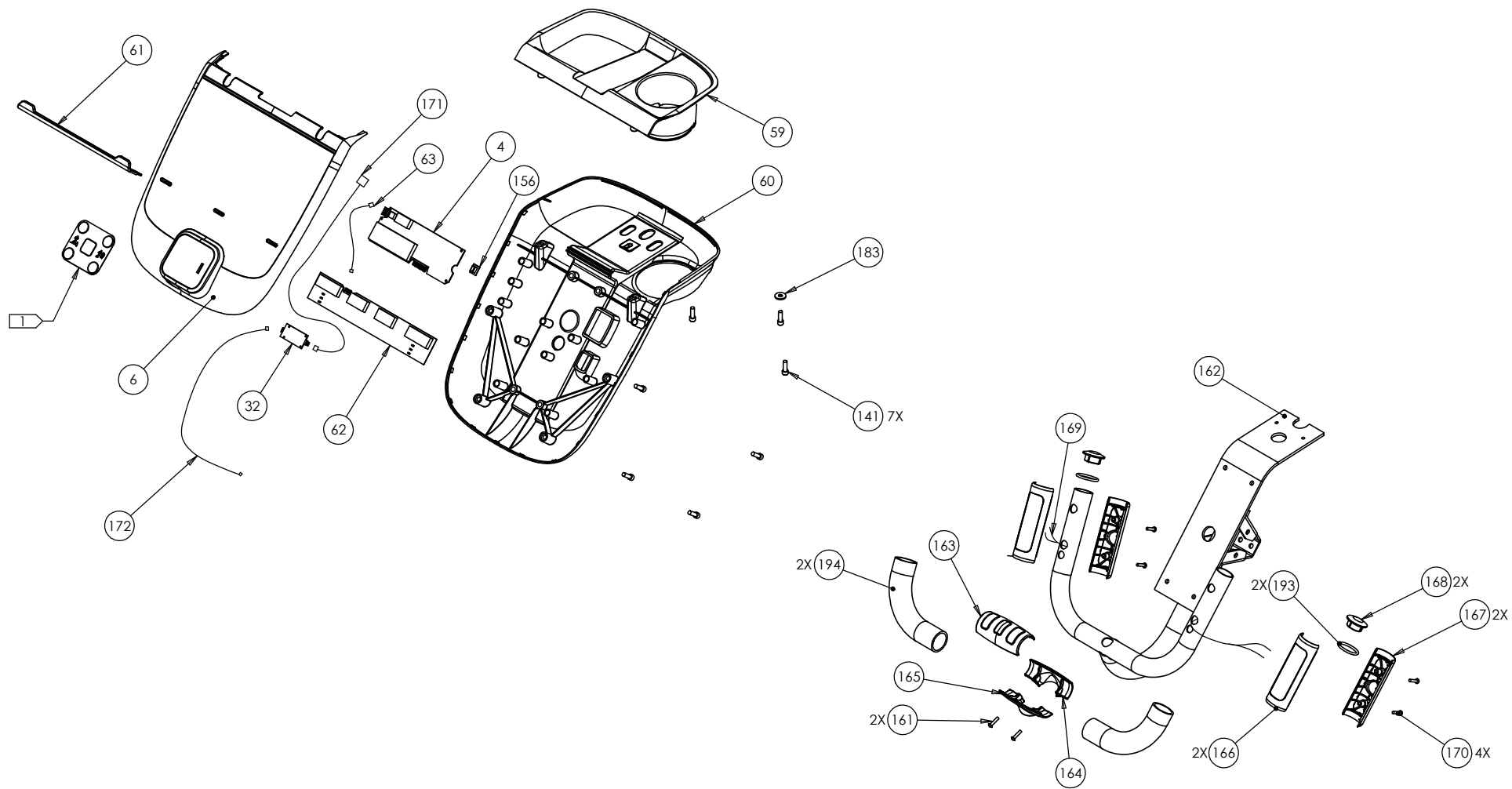

NOTES:

1 THE KEYPAD IS SUPPLIED AS PART OF THE DISPLAY ASSEMBLY, #6.
 IF THE KEYPAD IS REQUIRED INDIVIDUALLY, ORDER #175

5.35-07 - 240V	P/N: 34337-101	SUBREV : F
DRAWN BY : C THOMSON	DATE : 26 JUL 2011	SHEET 6 OF 6

5.35 (240V)(serial code AMWX)

Part Number	Description	Bubble Number
34249-106	ASSY, UPCA & SW, EFX 5.35-07	4
57033-101	DISPLAY ASSEMBLY, 5.35-07	6
300074-096	ASSY, CABLE, MOD, 8P8C, 1-1, W/FERR	7
44905-042	ASSY,CBL,MOD,8P8C,1-1,SILVER,42"	8
34246-102	ASSY, PCA & SW, EFX 5.3X-07, ARM LW	9
49806-036	ASSY, SPEED SENSOR, REED SWITCH, 03	11
34119-103	ACTUATOR, LIFT, CALIBRATED, W/O NUT	16
34125-101	ASSEMBLY, MOVING ARM, LEFT, 5.33-07	21
34125-102	ASSEMBLY, MOVING ARM, RIGHT, 5.33-0	22
47667-138	PWR CORD,250VAC,10A,CEE 7/7 - IEC 6	23
11415-102	COUPLER,MOD,8P8C,INLINE,SNAP-IN	29
38819-103	TRANSMITTER, POLAR T34, HEARTRATE,W	31
49401-102	BOARD, CHR & WIRELESS, SALUTRON	32
34123-101	ASSEMBLY, CROSSRAMP, ALPINE	44
49992-101	RAMP, LIFT, PIVOT BRACKET, ALPINE,A	45
57042-101	YOKE REPLACEMENT KIT, 5.31, 5.33, 5	46
34151-102	WELDMENT, STAIRARM RAIL, PAINTED, A	47
34171-107	WELDMENT, SIDE TUBE, LEFT, PAINTED,	50
34171-108	WELDMENT, SIDE TUBE, RIGHT, PAINTED	51
34251-104	OPPOSER, ARM PIVOT CLAMP, BLACK	52
TFTN25-088	SCREW,BTHD,1/4-20X7/8,BLK SHARPERIZ	54
34299-105	ASSEMBLY, LOWER LINK, LEFT, 5.35-07	55
34299-106	ASSEMBLY, LOWER LINK, RIGHT, 5.35-0	56
34189-101	PLASTIC, DISPLAY ACCESSORY TRAY, AL	59
34190-101	BACK PANEL, DISPLAY, ALPINE	60
48712-103	BOOK SUPPORT, DISPLAY-C, MAKROBLEND	61
48947-153	ASSY, PCA & SW, DISPLAY-C, METRICS,	62
49800-008	ASSY,CABLE, 6C,.1 CTR,1-1,TIN, W/FE	63
10123-105	CABLE TIE, 6 LONG,WHITE,NYLON	64
34180-101	COVER, DRIVE, BOTTOM, ALPINE	67
34221-103	ASSEMBLY, DRIVE COVER, FRONT	68
34222-102	ASSEMBLY, DRIVE COVER, SIDE, RIGHT	69
34222-101	ASSEMBLY, DRIVE COVER, SIDE, LEFT	70
34223-101	ASSEMBLY, DRIVE COVER, TOP	71
34224-101	ASSEMBLY, DRIVE COVER, ACCESS PANEL	72
34313-101	SLEEVE, RAMP PIVOT	73
34269-102	LABEL, WIRING DIAGRAM, 5.3X-07	74
47774-103	COVER, LPCA, 5.3X	76
AAHN063-003	RING, RETAINER, 5/8, EXTERNAL	77
CAGE050-200	SCREW,SKHD,1/2-13X2.00,BLK OXIDE	78
MGCN016-038	SCREW,MCH,8-32X3/8,PANHD,PHIL,	80
MNCN013-031	SCREW, MCH,6-32X5/16,FLTHD,PHIL	81
HWCN025-175	BOLT,SERRATED,GR5,1/4-20X1.75 ,FLNG	82
WAGNN062001	WASHER, WAVE, .87 OD X .62 ID	83
10136-103	CLIP,U TYPE, TINNERMAN, 1/4-20	84
12515-101	CLAMP, CABLE, BLACK, RELEASABLE ON	87
31074-104	FOOT, FIXED,	88
WAHNN075-001	WASHER, WAVE .750 ID X 1.072 OD X	89
WNNN063-001	WASHER, FLT, 5/8X.880X.010	91

37436-101	LABEL, CHASIS NEUTRAL	92
10136-103	CLIP,U TYPE, TINNERMAN, 1/4-20	93
12223-250	FUSE,TIME-DELAY,2.5A,250V,5X20MM	93
11075-105	FUSE,2.00A,250VAC,SLOW,RADIAL	94
35733-101	BADGE, PRECOR, 9.3X-07/5.2X-07	95
34207-101	ANCHOR, ACCESS PANEL	97
PMTN016-050	SCREW,TCS,#8X1/2,PHIL,BLK SHARPERIZ	98
12515-101	CLAMP, CABLE, BLACK, RELEASABLE ON	101
44437-005	CBL,1C,18AWG,#10 RING/187X032 QD RE	102
44437-018	ASSY, CABLE, GND,RING/QK DISC,18"	103
45109-078	ASSY,CBL,LPCA TO LIFT,78"	105
45742-101	WHEEL,846/842	106
PKCN019-075	SCREW,S/T,#10X.75,WSHHXHD,ZN	107
RATN038-050	SCREW,SHLD,3/8 X 1/2 ,HEXSC,BLK SH	108
WAMCN019-002	WASHER, LOCK, EXT TOOTH, #10	109
34111-101	WELDMENT, LIFT SUPPORT, MOVING ARMS	110
34185-101	COVER, LIFT, TOP, ALPINE	113
34186-101	COVER, LIFT, BACK, ALPINE	114
34188-101	MAG RACK, LIFT COVER, ALPINE	115
34219-103	ASSEMBLY; LIFT COVER; FRONT	116
WNNN081-003	WASHER,FLT,1.188-1.0X.027,STL	117
11476-102	PIN, RING, LOCKOUT	120
34306-101	RECEIVER, PIN, QUICK DISCONNECT	121
34138-101	BRACKET, LINK STOW/REAR COVER, PAIN	122
34276-101	ASSEMBLY, POWER ENTRY MOD/NEUTRAL L	123
CATN025-075	SCREW,SKHD,1/4-20 X 3/4,BLK SHARPER	124
WATNN025-002	WASHER, LK-INT, ID=.25,	125
HEME031-075	SCREW, GRADE 8, 5/16-18X.75,HEX CAP	126
WNNN032-009	WASHER,FLT, .321X1.00X.090 THK	127
10217-130	BELT, DRIVE, POLY V (DAYCO 27-0628)	128
10217-131	BELT, DRIVE, POLY V (DAYCO 27-0627)	129
11245-104	BUSHING,HEAVY DUTY PILLOW BLK	130
12866-101	ASSEMBLY, BANJO BOLT, WASHER, AND N	131
34161-102	WELDMENT, DRIVE, PAINTED, ALPINE	132
34213-101	ASSEMBLY, STEP-UP PULLEY, ALPINE	133
38320-104	IDLER,PULLEY	134
44300-103	ASSY, DRIVE INPUT, RETAIL	135
47553-1-02	RETAINER, SENSOR	136
47888-102	ELECTROMAGNET,EC BRAKE,.093" 2 POS	137
HCCN031-075	SCREW, HEX HD, GRADE 5, 5/16-18 X .	138
WBANN034-013	WASHER,FLAT,ID=11/32,OD3/4,TH=.125,	139
34168-101	ASSY, CRANK ARM, ALPINE	140
12647-101	PALNUT, SELF THREADING NUT, REG. TY	142
34206-103	RETAINER, STAIR ARM, BLACK	143
38301-101	ASSY,PIVOT BLOCK	144
57055-102	EFX PEDAL/TAPE KIT, ALPINE EFX'S	145
48337-101	ASSY, STAIRARM WHEEL, CONSUMER EFX,	147
CEGE006-014	SCREW, SKHD, M6 X 14, BLK OXIDE, W/	150
KDTN031-025	LOCKNUT, FULL, 5/16-18,BLK SHARPERI	151
RANN031-200	SCREW,SHLD,5/16 X 2,HEXSC	152
47023-102	COVER, LINK, FRONT, ALPINE	154
10123-102	CABLE TIE, 3-7/8 LONG,WHITE,NYL	155

12264-101	RJ-45 TELEPHONE JACK PLUG	156
12853-004	TAPE,POLYIMIDE FILM,SILICONE ADHESI	157
34141-101	WELDMENT, DISPLAY SUPPORT WITH HAND	162
34208-101	COVER, HHR ACCESS HOLE	163
34226-101	COVER, HHR ACCESS HOLE, TOP	164
34226-102	COVER, HHR ACCESS HOLE, BOTTOM	165
42713-102	HHR SENSOR, TOP	166
42714-102	HHR SENSOR, BOTTOM	167
42730-101	PLUG, HHR, HANDLE BAR END	168
48421-032	ASSY, CABLE, HHR GRIP, W/SHIELD, 32	169
TCNN016-075	SCREW, BTHD, 8-32X.75, SS	170
35755-024	ASSY, CABLE, HHR TO DISPLAY, 24"	171
49893-018	ASSY, CBL, HSG TO MINI-FIT REC, 4P4C, 1	172
34210-101	COVER, DISPLAY BRACKET, TOP	173
34210-102	COVER, DISPLAY BRACKET, BOTTOM	174
34214-101	KEYPAD, SNAP DOME, 5 BUTTON, EFX, A	175
TFTN025-075	SCREW, BTHD, 1/4-20X3/4, BLK SHARPERIZ	176
34275-104	ASSEMBLY, WEDGE/DECALS	177
TFTN025-075	SCREW, BTHD, 1/4-20X3/4, BLK SHARPERIZ	178
34204-101	BADGE, REAR COVER, EFX, ALPINE	179
33984-101	LABEL, SAFETY, GROUND SYMBOL	180
10178-107	BUSHING, SNAP	181
KMCN044-038	NUT, HEX, 7/16-14, ZN	182
WBCN025-006	WASHER, FLT, 1/4X.500X.063, ZN (MECH	183
FAGN025-028	NUT, CONNECTOR, JOINT	185
FBGN025-091	BOLT, CONNECTOR, JOINT, 29/32 LONG	186
34205-101	BADGE, LIFT COVER, PRECOR, ALPINE	187
34265-103	DECAL, LINK ATTACHMENT, STAIR ARM 5	188
WBCN031-007	WASHER, FLT, 5/16X.688X.065, ZN	189
34211-101	COVER, LINK END, TOP, ALPINE	190
34211-102	COVER, LINK END, BOTTOM, ALPINE	191
MGTN013-075	SCREW, MCH, 6-32X3/4, PANHD, PHIL, BLK S	192
10115-113	O-RING, ROUND, 1.25ID X .139	193
34277-101	GRIP; HANDLEBAR; EXTRUDED VINYL, 6.75	194
34266-101	DECAL, LINK ATTACHMENT, COVER, LEFT	195
KRCN050-031	NUT, HEX THIN, UNF, 1/2-20, ZINC	197
301561-101	ASSY, AUTO-TRANSFORMER, STEP DOWN,	198
34272-108	KIT, HARDWARE, 5.33/5.35/5.37, RED	200
11095-109	ENDCAP, HEYCO (2633DOM)	201
WAHNN080-021	WASHER, WAVE .800 ID X 1.103 OD X	365
WNNN075-001	WASHER, SHIM, .75X1.50X.010 THK	369
AAHN078-004	RING, EXTERNAL, .781, .042 THK	373
10186-107	WRENCH, ALLEN, 7/32	902
11406-103	FOOT, LEVELER, RUBBER BASE, 1.5" LG	903
HCCN031-075	SCREW, HEX HD, GRADE 5, 5/16-18 X .	905
KDCN038-034	LOCKNUT, FULL, 3/8-16, BLK ZN	906
KPCN031-019	NUT, HEX THIN, 5/16-18, ZN	907
TCNN038-275	SCREW, BTHD, 3/8-16X 2.75, SS	910
WBCN031-007	WASHER, FLT, 5/16X.688X.065, ZN	911
WPNN038-006	WASHER, FLAT, 3/8 X 1/16 THK,	912
10186-117	WRENCH, ALLEN 5MM	913
FAGN025-028	NUT, CONNECTOR, JOINT	914

FBGN025-138	BOLT, CONNECTOR, JOINT	915
WATCHN041-002	WASHER, LK-INT, ID= .406,	917
10186-121	WRENCH, ALLEN, 5/32, LONG	918
34235-104	LITERATURE KIT, EFX 5.33/5.35-07	999